

ID TECHNOLOGY

EPI-9230

Pressure Sensitive Labeling System for
Top/Bottom & C-Wrap Labeling

This hybrid labeling system is a combination of ID Technology's Top/Bottom System and C-Wrap System that integrates right into your specific packaging process.

EPI-9230 comes with a full belt infeed conveyor and a split belt outfeed conveyor. It uses two of the proven M-Series labeling heads to dispense the labels. Labels can be applied around the top, front and bottom of a clamshell container or the top and/or bottom of the packaging.

It features simple vertical and horizontal adjustments to allow for quick and reliable label placement. After the label is applied to the package there is a dual wiping mechanism that firmly secures the labels.

EPI-9230 is a great labeler to ensure that containers remain closed from the packaging line all the way to the retail shelf.

The EPI-9230 is ideal for baked goods, produce, confectioneries, clamshells and more.

The EPI-9230 is made with corrosion resistant materials and is designed to withstand harsh conditions.

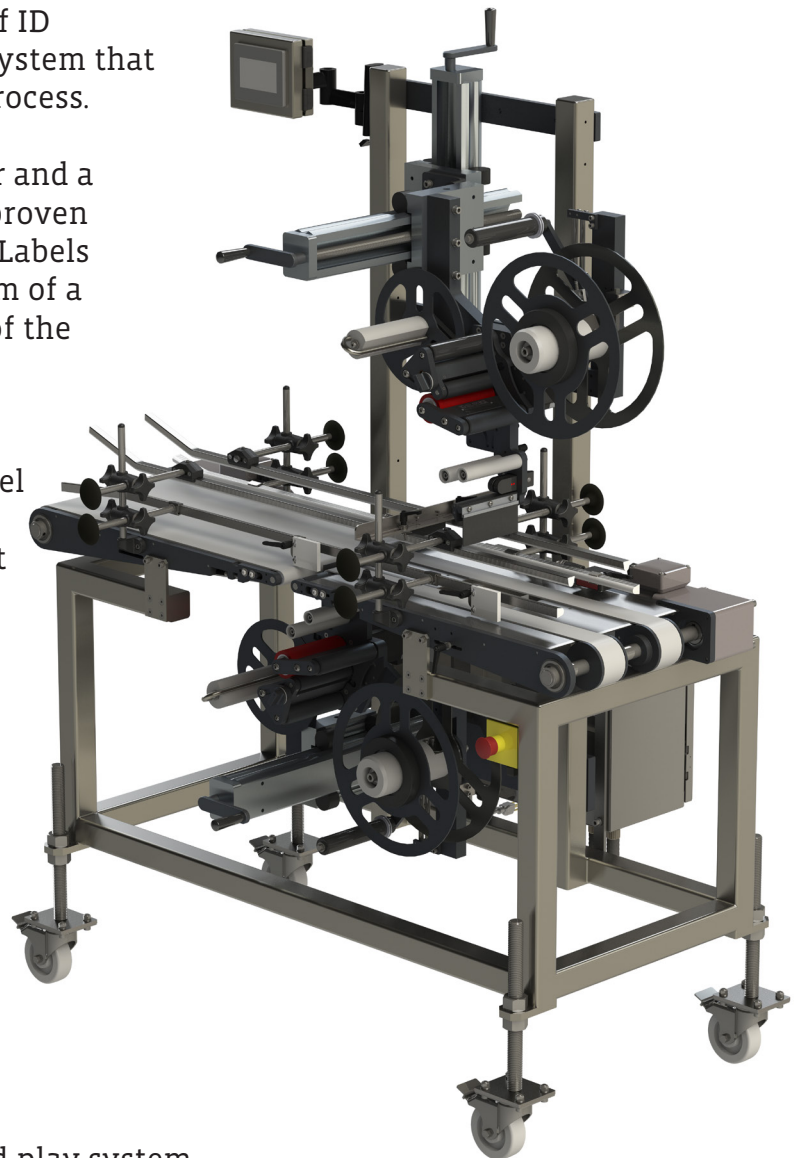

Key Features

- Consolidated electrical controls for a plug and play system.
- Easy to navigate full color touchscreen for both top and bottom labelers.
- Standard encoder speed matching capabilities.
- High torque stepper motors used for precision accuracy.
- Fast changeover capabilities with tool-less adjustments.

EPI-9230 Pressure Sensitive Labeling System

The 9000 Series is a range of robust, competitively priced labeling equipment designed to handle a wide range of applications. 9000 Series products are built in the USA, in our production facilities in Oakland, NJ, New Freedom, PA and Fort Worth, TX. With nationwide on-site support and six label printing plants, ID Technology can help streamline and enhance your labeling operations.

Features

Label Size: 1" x 1" to 5" x 12" (5"x24" for C-Wrap, top labeling head only)
Smaller/Larger size optional

Label Supply: 12" OD on a 3" core
Larger size optional

Product Size: 4" - 12" Wide - Standard
2" to 24" Long - Standard
Larger sizes optional

Electrical: 6A @ 120VAC, 60 HZ

Speed: Variable up to 100 FPM

Conveyor: Stainless Steel, Aluminum,
UHMW, Powder Coated Steel

Options:

- 16" Label Supply
- Increased Label Width
- Low Label Supply Warning with Auto Shut-Off Feature and Beacon Light
- Different Supply Voltage
- Clear Label Sensor Package
- Washdown Package
- Additional Conveyor Width
- Additional Conveyor Length
- Adjustable Feet
- Higher Speed

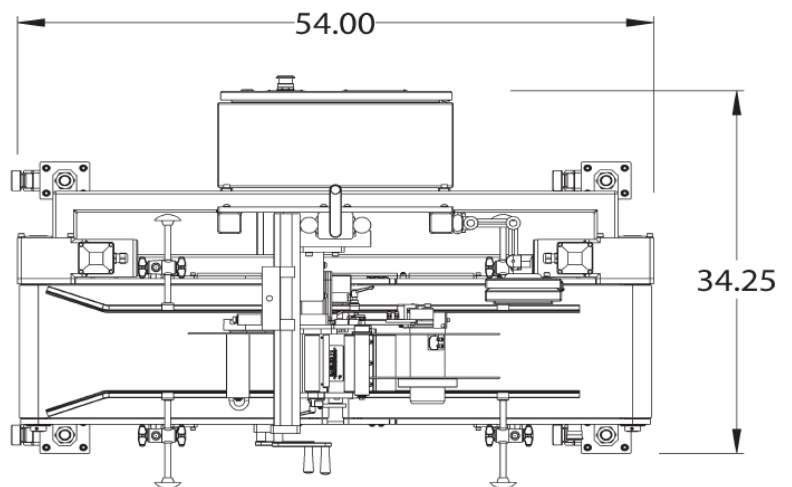
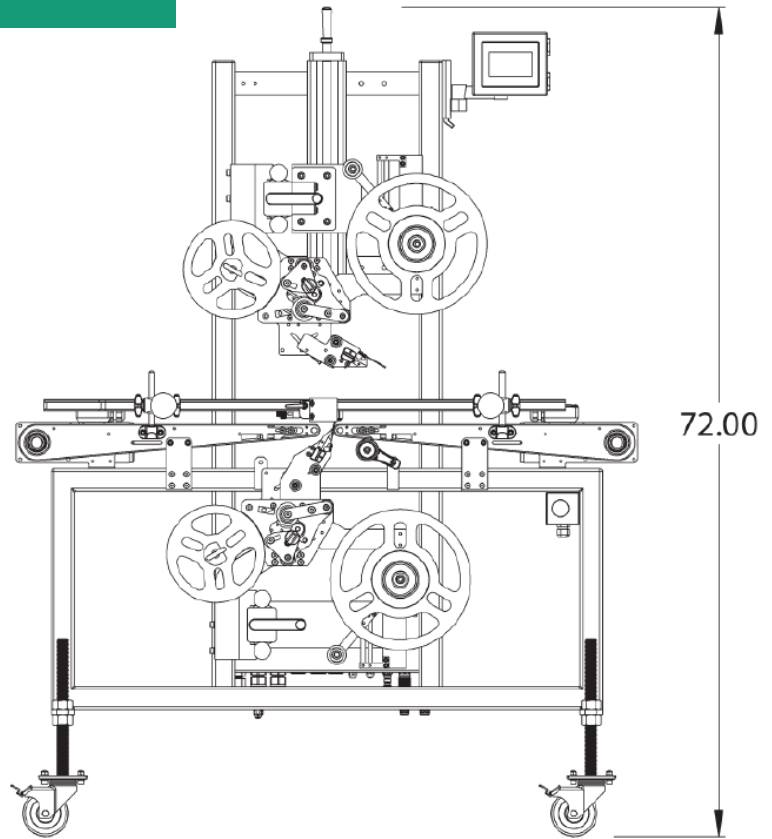

*Complimentary
Lifetime Equipment Warranty*

For customers using ID Technology labels on our labeling equipment, we offer a lifetime limited equipment warranty.

GEORGE R. DOUGLAS
ASSOCIATES, LLC *Since 1930*

3261 Commercial Parkway • Memphis, TN 38116
Tel: (901) 332.6735 • Toll Free: 1-866-804-5291 • Fax: (901) 332.1834

E-mail: grdouglas@grdouglas.com • Visit: grdouglas.com